

Art. 24 Mehrlängenzuschlag (MLZ)

Messweise

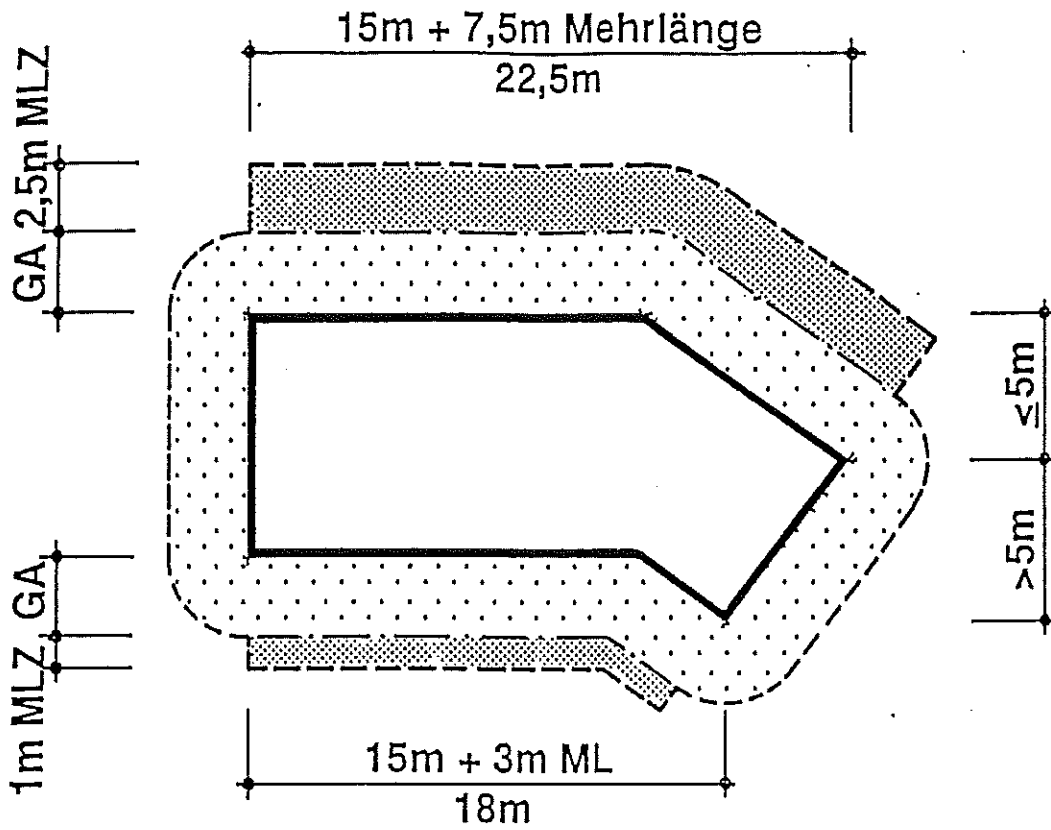

$$MLZ 1 = \frac{25 - 15}{3} = 3,33$$

also 3m

$$MLZ 2 = \frac{18 - 15}{3} = 1m$$

$$GA = 3m$$

Beispiel W2

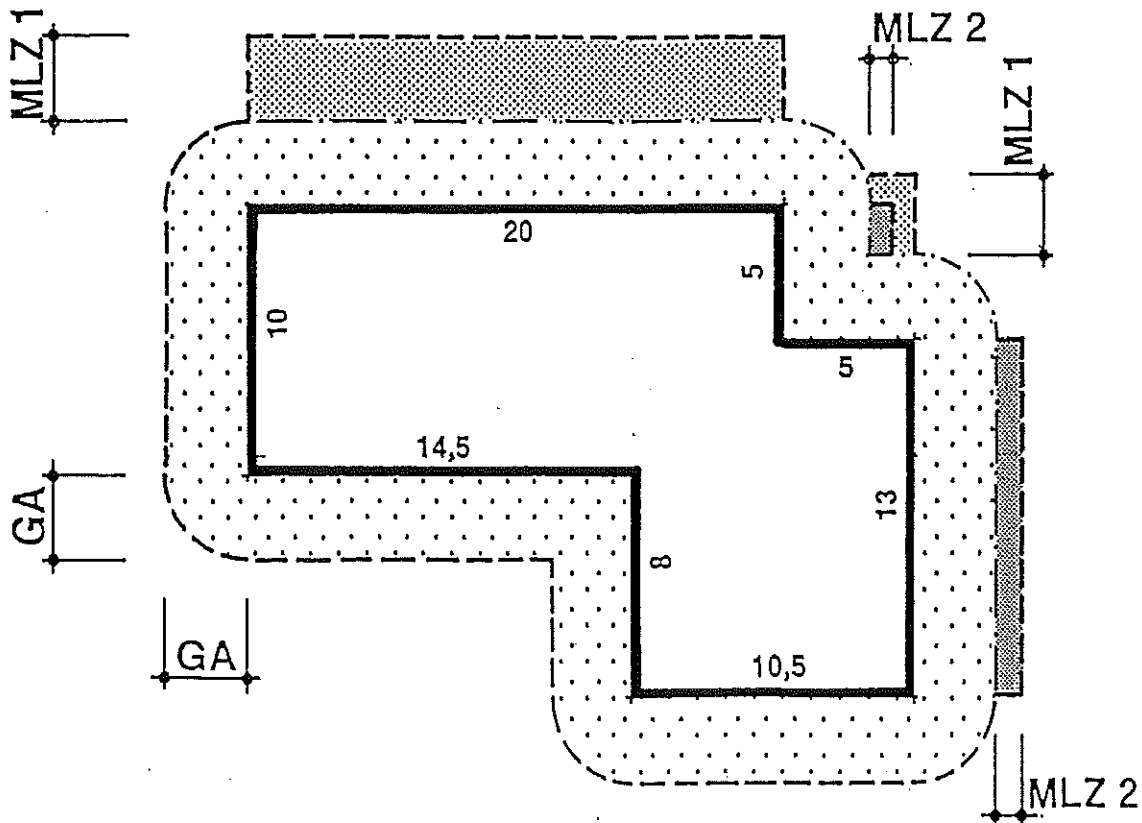

Art. 31.3 Attikageschoss

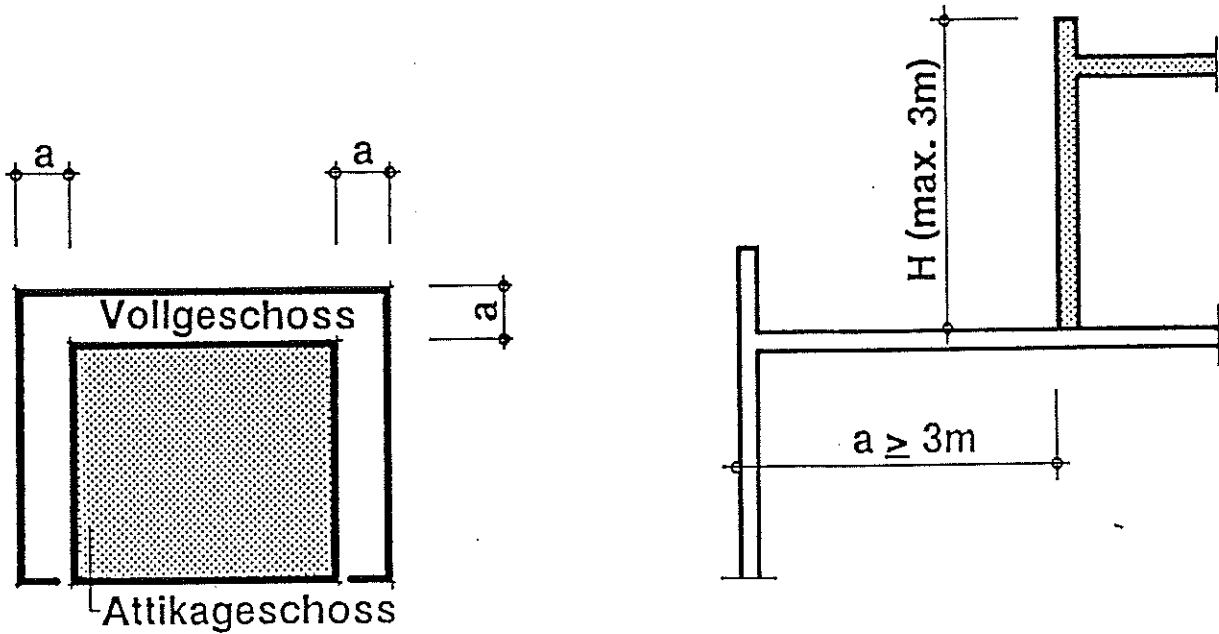

Art. 34 Dachfirsthöhe, Kniestockhöhe Art. 35.1

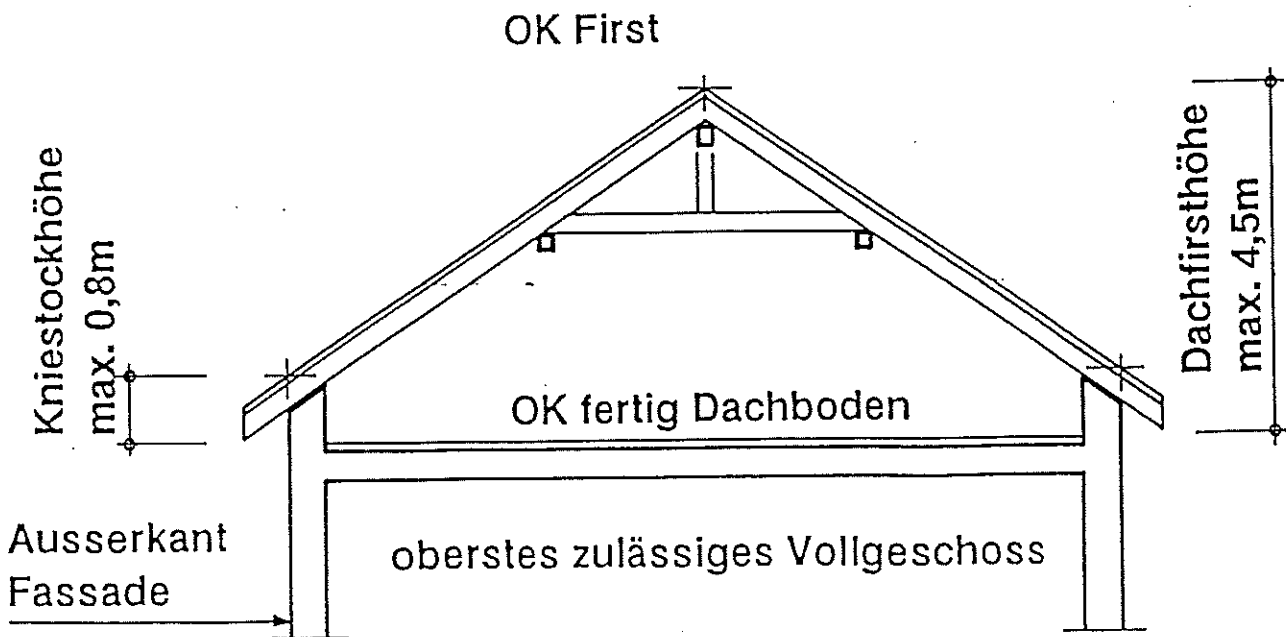

Art. 32 anrechenbare Geschosse (Beispiel W2)

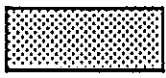

hinausragende Aussenwandfläche
des Untergeschosses
(summiert über alle Fassaden)

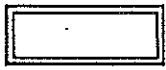

Aussenwandfläche des Untergeschosses
(OK fertig UG-Boden bis OK fertig EG-Boden
summiert über alle Fassaden)

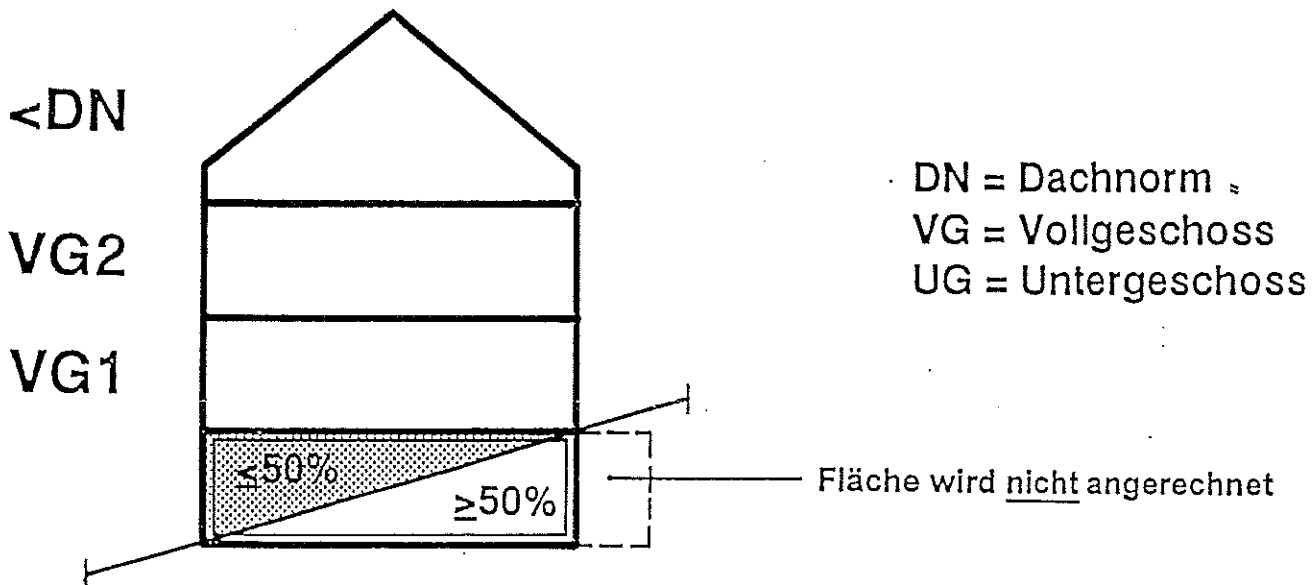

UG nicht angerechnet

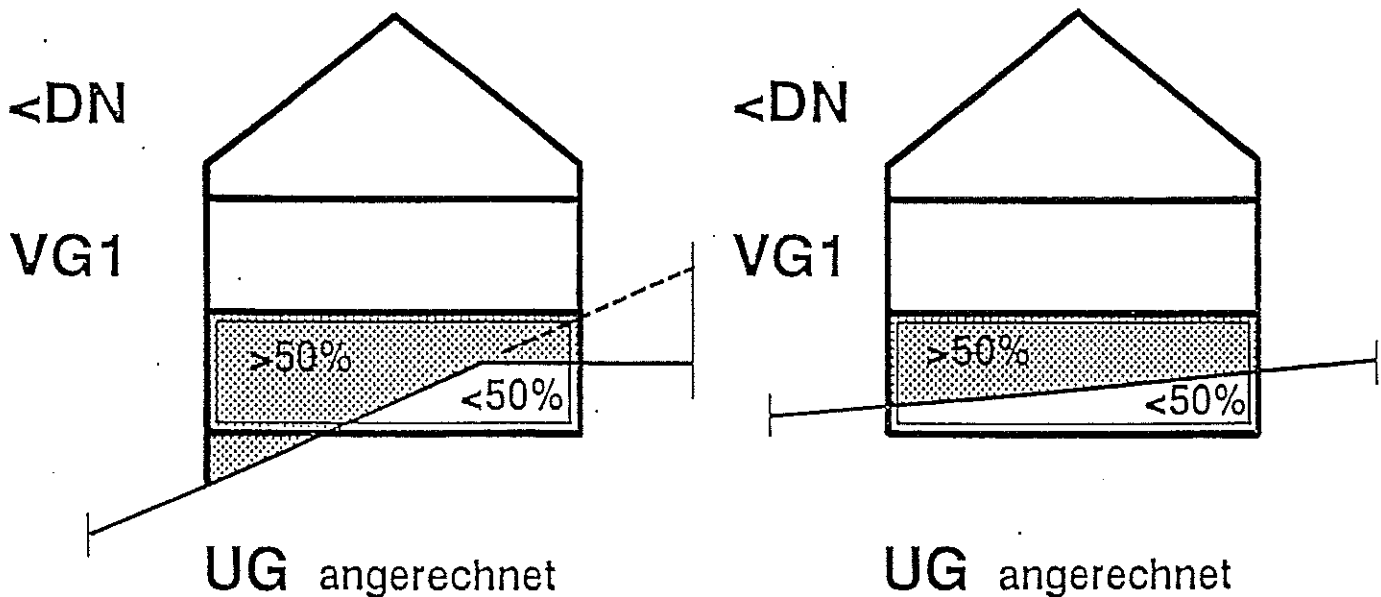

Art. 35.3 Dachaufbauten

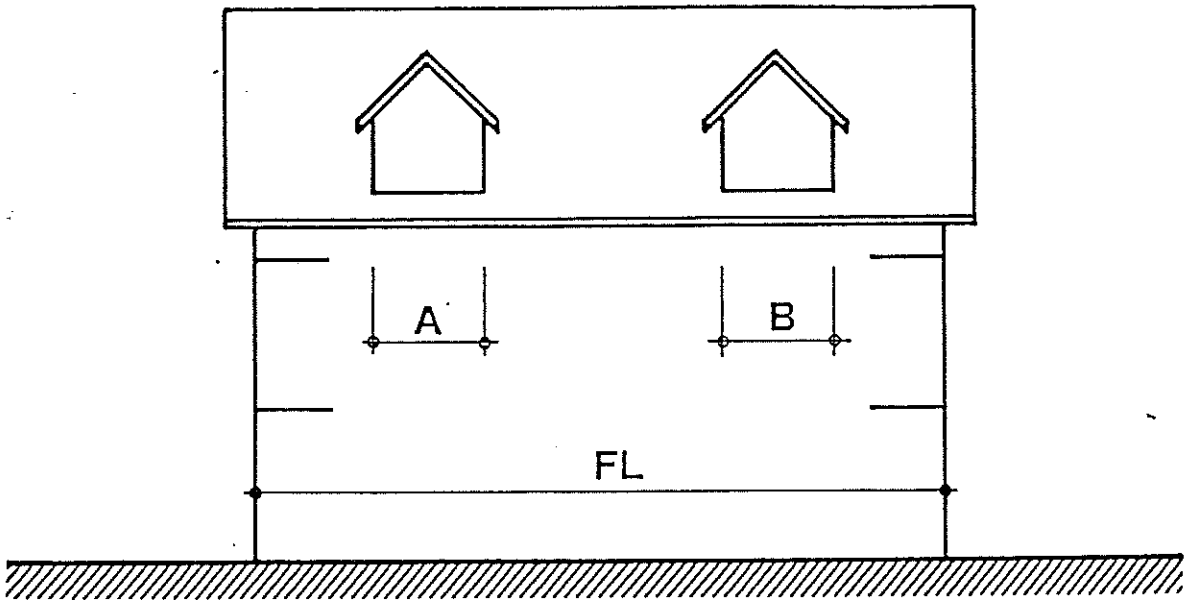

FL = Fassadenlänge

$A + B = \max. 1/3 FL$

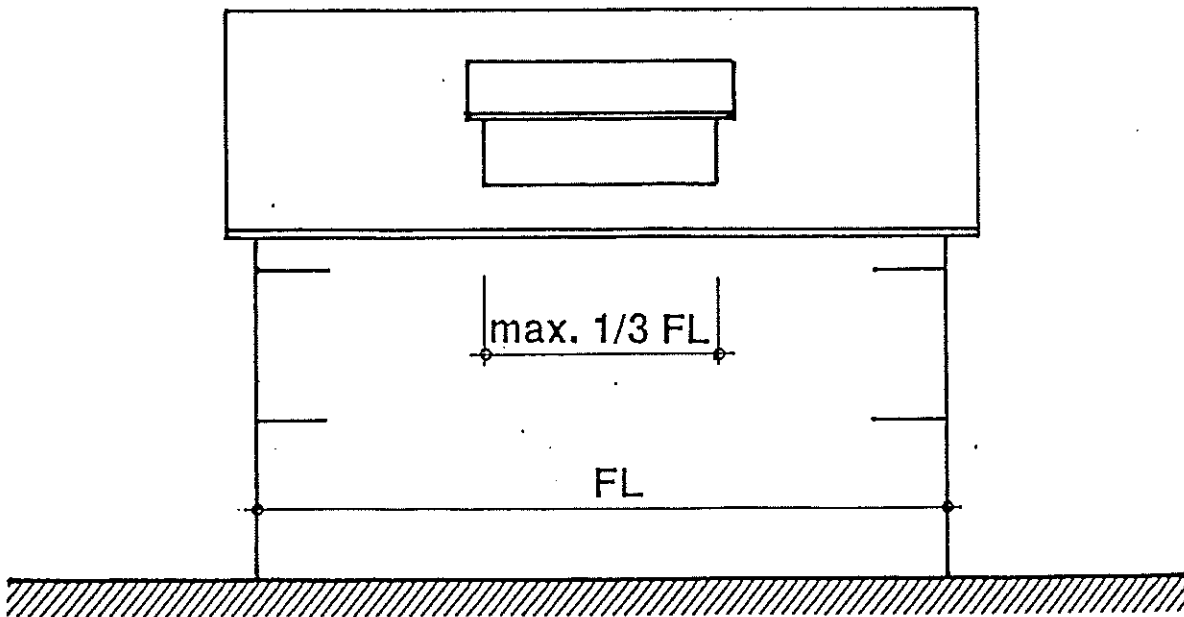

Art. 35.1 Dachbegrenzungslinie, Dachformen

Art. 35.2

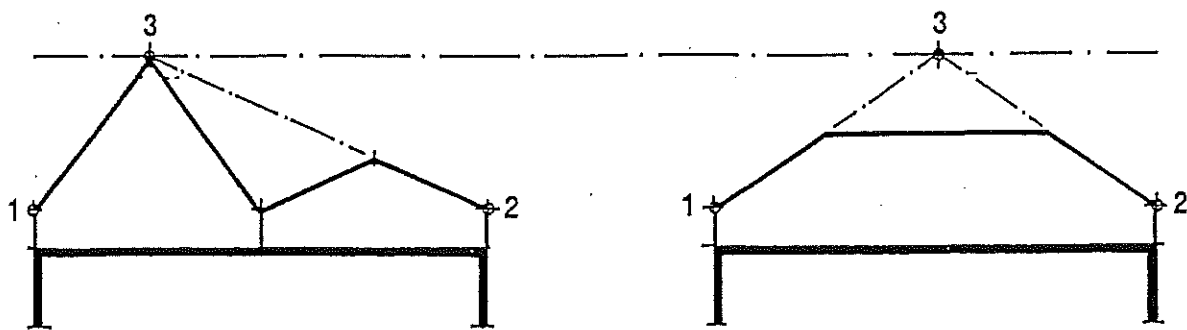
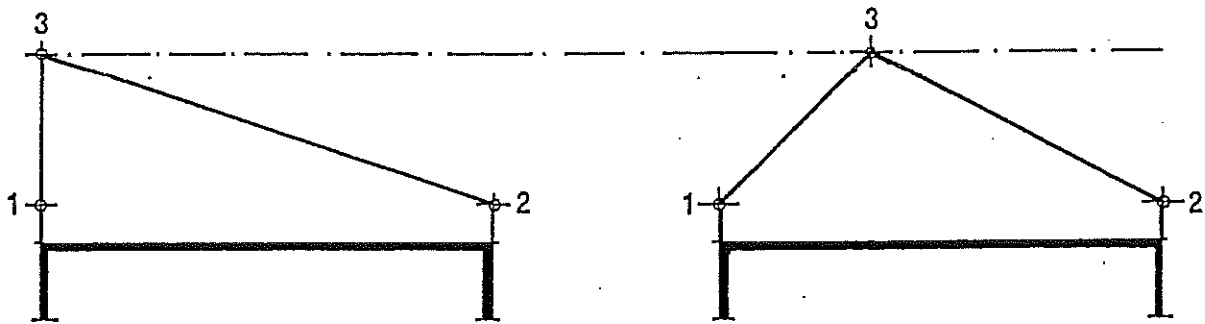
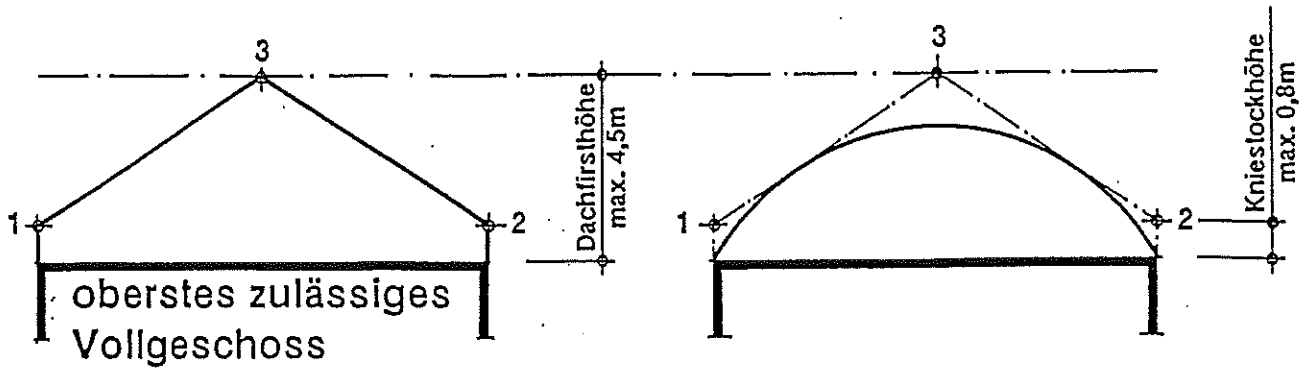

Art. 36.1 Maximale Gebäudehöhe

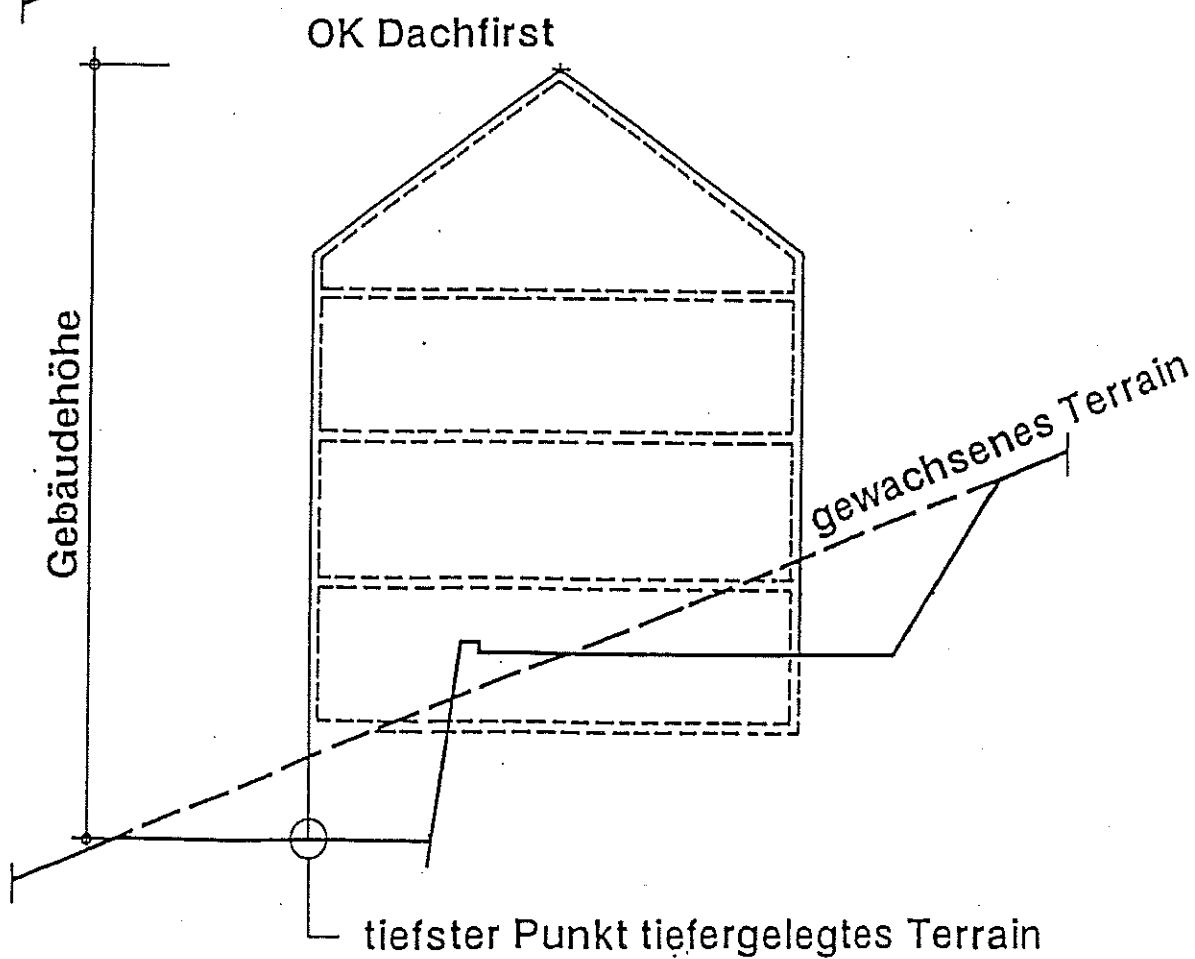
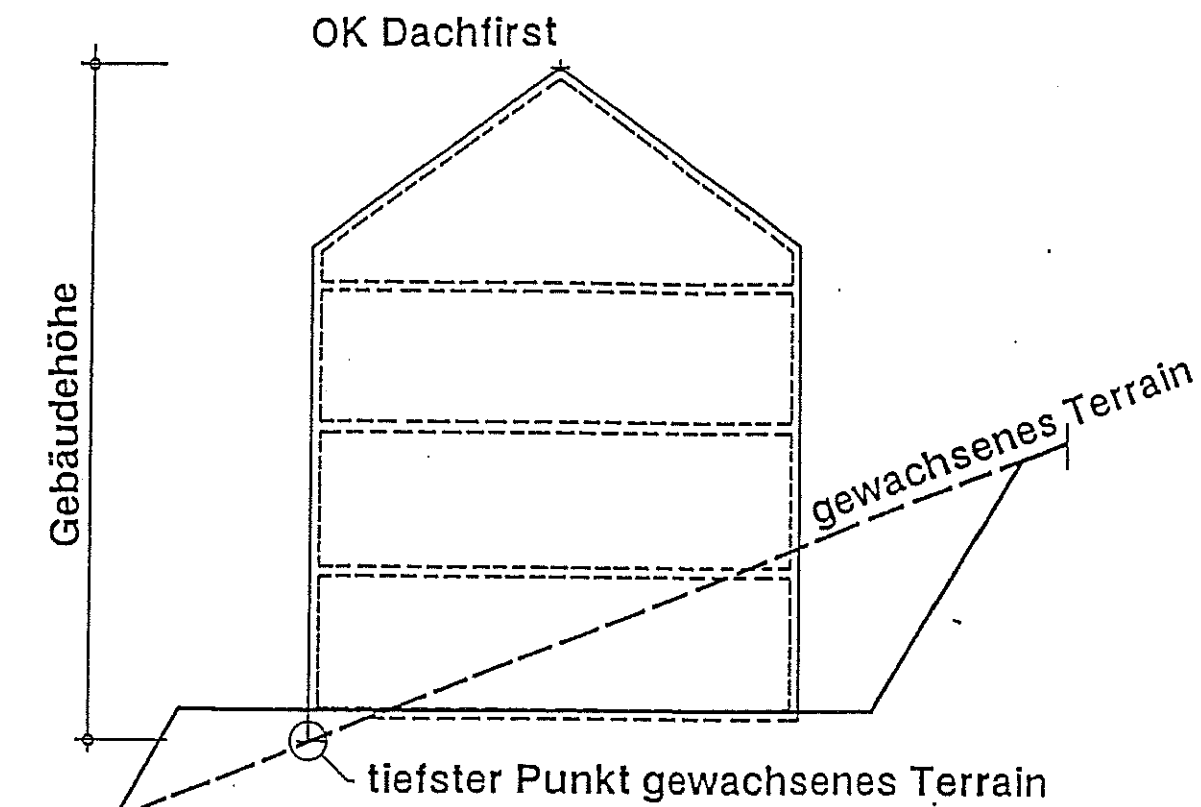

Art. 37.1 Baulänge

